

PIO-HV



- 24 bits of digital I/O
- 8 output bits, 8 input bits, plus 8 bits selectable as input or output
- Outputs switch 25mA up to 50 volts
- Inputs monitor up to 32 volts
- 32-bit DriverLINX drivers plus a suite of bundled software including ExceLINX, VisualSCOPE, TestPoint, and LabVIEW drivers

Ordering Information

PIO-HV 24-Bit, High-Voltage Parallel Digital I/O Board with ASO-PIO Software

APPLICATIONS

- Contact monitoring
- Relay control
- Parallel communications
- Process control
- Energy management
- Display drivers

ACCESSORIES AVAILABLE

C1800	PIO-HV to STA-U Cable
C1800/M	PIO-HV to STP-37/FC Cable
STA-U	Universal Screw Terminal Accessory
STP-37/FC	Screw Terminal Panel with female D37 connector
STC-37	Direct Screw Terminal Connector
TESTPOINT	TestPoint Software Package

1.888.KEITHLEY (U.S. only)

www.keithley.com

24-Bit, Open Collector, High Voltage Digital I/O Board

Functional Description

Keithley's PIO-HV is a 24-bit parallel interface which allows the control and monitoring of digital signals with voltages greater than standard 5-volt logic levels. It supports up to 50V, allowing you to connect your own arbitrary logic power supply, and it can drive very high currents. It also provides open-collector digital I/O. The board was designed to be used with IBM PC/XT/AT and compatible computers.

Most digital I/O boards are designed to interface directly with +5 volt logic signals (e.g., LSTTL or NMOS families). To interface a standard logic level board to higher voltages requires external signal conditioning which is both expensive and bulky. Some digital output boards use electromechanical relays to expand their output capability. Though these relays work well in many applications, their low switching speed, high power consumption, and relatively short life make their use inadvisable in many applications. The PIO-HV with its high-voltage input and output capabilities provides a compact, inexpensive alternative to external signal conditioning and relay solutions.

The PIO-HV's 24 bits are divided into three 8-bit ports. Port A is an 8-bit output port, port B is an 8-bit input port, and port C is switch-selectable as input or output. This switch can be set through the PIO-HV rear panel, allowing Port C direction to be changed without opening the computer. The output ports are open collectors and will switch 25 milliamps at up to 50VDC. The input ports will monitor voltages up to 32VDC with a switching threshold of 3.2VDC.

All connections to the PIO-HV are made through a 37-pin D connector which extends out the rear of the host computer. The user can wire directly to a mating 37-pin connector (part #SFC-37) or use a screw terminal board such as the STA-U or STC-37 to simplify field wiring.

Connector Pin Assignment

All digital I/O is through a standard 37-pin D-type male connector that projects through the rear panel of the computer. For soldered connections, a standard 37-pin D female (ITT/Cannon DC-37S or equivalent) is the correct mating part, and can be ordered from Keithley as part #SFC-37.

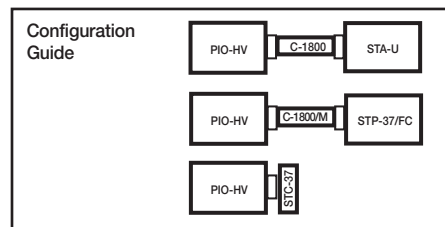
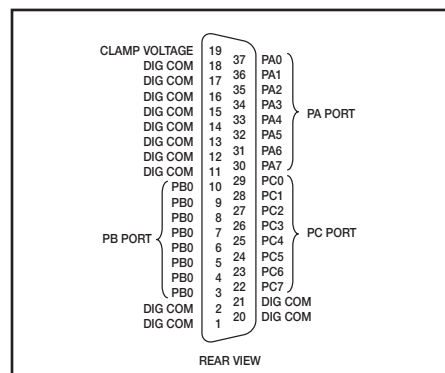

SPECIFICATIONS

PORT A - OUTPUTS

OF BITS: 8.
CONFIGURATION: Open collector.
MAXIMUM VOLTAGE: 50V
OUTPUT CURRENT: 25mA at less than 1V

PORT B - INPUTS

OF BITS: 8.
CONFIGURATION: Common ground (single ended).
INPUT IMPEDANCE: 1500Ω.
INPUT HIGH LEVEL: Greater than 3.5V (at 1.5mA).
INPUT LOW LEVEL: Less than 2V or open circuit.
MAXIMUM INPUT: 32V

PORT C - OUTPUTS

OF BITS: 8.
CONFIGURATION: Open collector.
MAXIMUM VOLTAGE: 50V
OUTPUT CURRENT: 25mA at less than 1V

PORT C - INPUTS

OF BITS: 8.
CONFIGURATION: Common ground input.
INPUT IMPEDANCE: 1500Ω.
INPUT HIGH LEVEL: Greater than 4.0V (at 2.0mA).
INPUT LOW LEVEL: Less than 2V or Open Circuit.
MAXIMUM INPUT: 32V

ENVIRONMENTAL

OPERATING TEMP: 0 to 50°C.
STORAGE TEMP: -20 to 70°C.
HUMIDITY: 0 to 90% (non-condensing).
EMC: Conforms to European Union Directive 89/336/EEC.
WEIGHT: 4oz (120g).
DIMENSIONS: 7.0in L × 4.25in H × 0.85in D (17.8cm × 10.8cm × 2.2cm).

KEITHLEY